

- High selectivity type ceramic filters
- A variety of bandwidths available
- Easily mounted to PCB
- Miniature size

## 6 Element

### SPECIFICATION

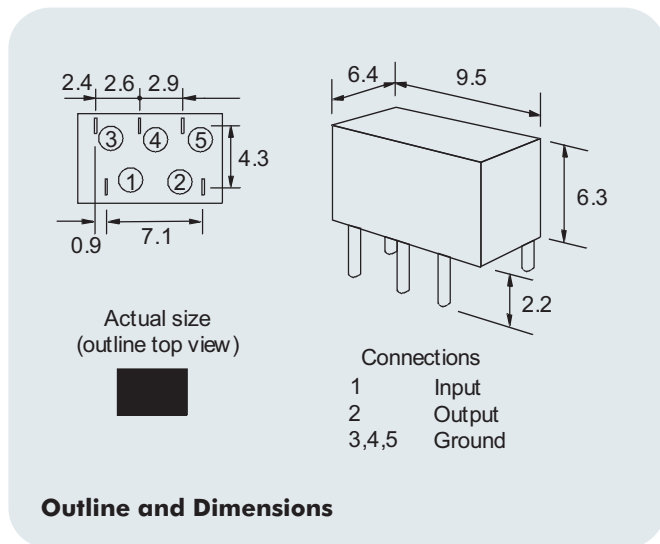

### Frequency v. Attenuation Characteristics

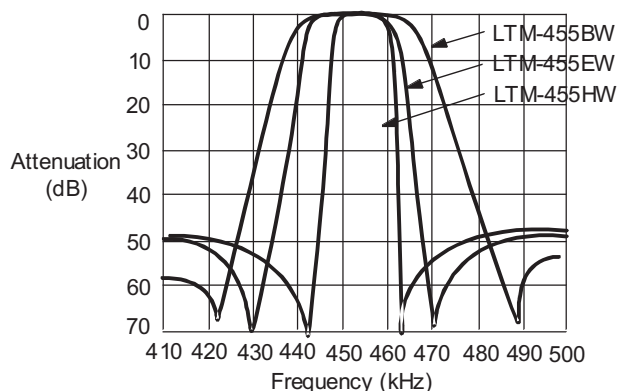

### ELECTRICAL CHARACTERISTICS

Part Number	Centre Frequency (kHz)	Insertion Loss (dB max.)	Pass Band Ripple (dB max.)	6dB Bandwidth (kHz min.)	50dB Bandwidth (kHz min.)	Stop Band Att. $\pm 100$ kHz (dB min.)	Input/Output Impedance ( $\Omega$ )
LTM 455BW	455 $\pm$ 2	4	2	$\pm 15$	$\pm 30$	45	1500
LTM 455CW	455 $\pm$ 2	4	2	$\pm 12.5$	$\pm 24$	45	1500
LTM 455DW	455 $\pm$ 1.5	4	2	$\pm 10$	$\pm 20$	45	1500
LTM 455EW	455 $\pm$ 1.5	6	2	$\pm 7.5$	$\pm 15$	45	1500
LTM 455FW	455 $\pm$ 1.5	6	2	$\pm 6$	$\pm 12.5$	45	2000
LTM 455GW	455 $\pm$ 1.5	6	2	$\pm 4.5$	$\pm 10$	45	2000
LTM 455HW	455 $\pm$ 1.0	6	2	$\pm 3$	$\pm 9$	55	2000
LTM 455IW	455 $\pm$ 1.0	6	2	$\pm 2$	$\pm 7.5$	55	2000
LTM 455HTW	455 $\pm$ 1.0	6	2	$\pm 3$	$\pm 9$	60	2000
LTM 455ITW	455 $\pm$ 1.0	6	2	$\pm 2$	$\pm 7.5$	60	2000

### TEST CIRCUIT

